

APPLICATION:

PRODUCT NAME:
1/2" ELBOW

JOB NAME:

MODEL:
 2400-2103 1/2" F X 1/2" F ELBOW

QUANTITY:

ITEM NO.

OPTIONS OR MODIFICATIONS:
 OTHER _____

FEATURES

- * FITS ALL COMPETITOR'S COMMERCIAL FAUCETS
- * 1/2" 90° ELBOW TO MAKE INSTALLATION EASIER WHEN YOU ARE LIMITED ON SPACE, BEHIND THE BACKSPASH
- * PREVENTS ANY CRIMPING OR OTHER DAMAGE TO SUPPLY LINES

SHIPPING WEIGHT
* 0.375 LBS

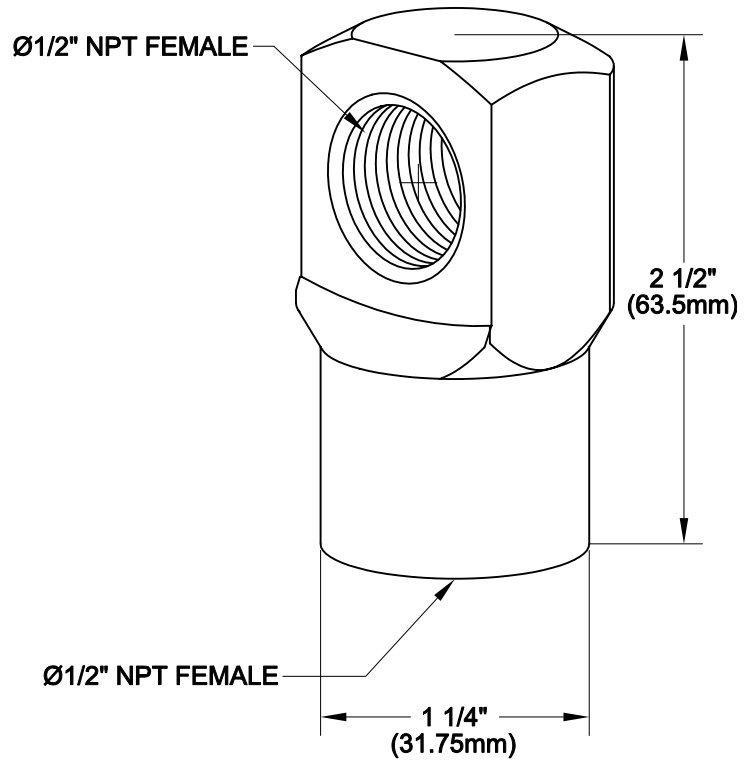

ANSI/A112.18.1M

FISHER

FISHER MANUFACTURING COMPANY

TOLL FREE: 800-421-6162 - FAX: 800-832-8238

information@fisher-mfg.com - www.fisher-mfg.com